

Wireless terahertz light transmission based on digitally-modulated terahertz quantum-cascade laser

Zhiyong Tan (谭智勇)¹, Zhen Chen (陈 镇)¹, Juncheng Cao (曹俊诚)^{1*}, and Huichun Liu (刘惠春)²

¹Key Laboratory of Terahertz Solid-State Technology, Shanghai Institute of Microsystem and Information Technology, Chinese Academy of Sciences, Shanghai 200050, China

²Key Laboratory of Artificial Structures and Quantum Control, Department of Physics, Shanghai Jiao Tong University, Shanghai 200240, China

*Corresponding author: jccao@mail.sim.ac.cn.

Received August 14, 2012; accepted October 10, 2012; posted online February 6, 2013

A wireless terahertz digital transmission link is demonstrated, in which a quantum-cascade laser and a spectrally-matched quantum-well photodetector serve as the emitter and receiver, respectively. An on-off modulation scheme is used. By directly amplitude modulating the laser emitting at 4.13 THz, a 1.0-Mbps pseudorandom signal is transmitted over a distance of 2.2 m.

OCIS codes: 140.5965, 040.2235, 060.2605.

doi: 10.3788/COL201311.031403.

There are huge bandwidth resources in the terahertz (THz) range. THz wireless communication is a promising type of future information technology^[1]. However, the emitter and receiver are not mature enough to build a real THz communication system, especially in the 2.0–5.0 THz range. The THz quantum-cascade laser (QCL) is one of the most promising sources in this frequency region, and has many advantages such as compact size, portability, long life-time, and easy integration^[2–4]. Fast modulation^[5,6] of THz QCLs, such as the midinfrared QCLs^[7], is a key element of transmission systems with high data-rate. Moreover, a spectrally-matched detector with fast response ability, such as the quantum-well infrared photodetector (QWIP)^[8], is also required. Audio wireless transmission systems have been demonstrated in Refs. [9,10], in which pulsed and continuous-wave (CW) THz QCLs are employed, respectively. In this letter, we report a direct amplitude modulation of a 4.13 THz, CW QCL device by employing a pseudorandom signal. A transmission link is built using this THz QCL and a spectrally-matched THz quantum-well photodetector (QWP) with a good response in the 3.1–5.0 THz range^[11]. The practical transmission rate of the link is measured. The main factor that limits the transmission rate of the system is also discussed.

The emitting frontend consisted of a QCL device based on a four-well resonant-phonon design, with a metal-metal waveguide (length: 1 mm, width: 30 μm) and a home-made modulator. The optical and electrical properties of the laser are detailed in Ref. [12]. The receiver consisted of a large-area QWP device, with a size of 1.5 \times 1.5 (mm). The receiver was based on a GaAs/AlGaAs material system, grown by molecular beam epitaxy (MBE) and a home-made signal processing circuit. Both devices worked at cryogenic temperature. The QCL that operated at 13 K, was fixed to a copper heat sink and then mounted onto the cold finger of a closed-cycle helium cryostat. The QWP was cooled down to 4 K by a continuous-flow liquid-helium cryostat. A schematic of the transmission setup is shown in Fig. 1.

As shown in Fig. 1, the QCL is driven by a home-made modulator circuit, the input of which is a pseudorandom signal in transistor-transistor logic (TTL) provided by a bit error rate (BER) analyzer (Fig. 1). In such system, the circuit controls the output signal, which leads to a high and low level switching. The laser also emits a 4.13-THz pseudorandom-like THz light, with an average power of about 1 mW, thereby realizing an on-off modulation. Here, the driven voltage added to the laser was 7.8 V in low level (no radiation) and 13.5 V (emitting radiation) in high level. In addition, overload protection and impedance matching were applied in this circuit. Using two off-axis parabolic (OAP) mirrors with a focal length of 101.6 mm, the emitted pseudorandom-like light from the QCL was transmitted through a 2.2-m optical path in free space, and then focused onto the QWP mesa. The bias voltage added to the QWP was –30.5 mV. The current generated in the QWP was extracted to a voltage signal by the signal processor, in which a trans-impedance amplifier and a variable gain amplifier were used. The current was made to flow through a low-pass filter to eliminate the high frequency excess noise caused by the QWP device. Alternating current (AC) coupling was used in the circuit. Finally, the signal was fed into an oscilloscope.

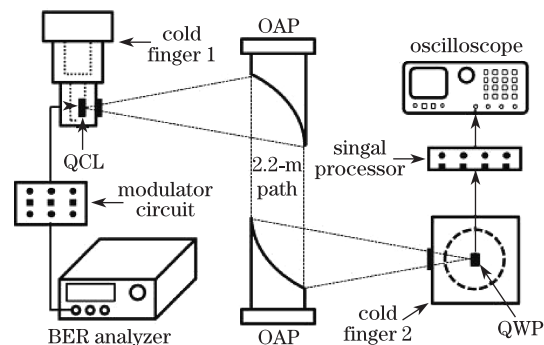

Fig. 1. Scheme of the transmission setup based on a digitally-modulated THz QCL.

The profile of the THz light beam at the focus point of the second OAP was measured using a thermal detector array. The photograph of the displayed result is shown in Fig. 2. As can be seen, the THz light is gathered at the focus point.

A 1.0-Mbps signal is transmitted through the 2.2-m link. The time traces of the modulated signal (upper part) and demodulated digital signal (lower part) are shown in Fig. 3, with a time scale of $5 \mu\text{s}$ per division. The inverting original signal generated by the detector, which has a time scale of $5 \mu\text{s}$ per division, is also shown in Fig. 4. From the graph, we can see that the signal-to-noise (SNR) of the original signal is bad and with a value of about 1. The received signal also shows a delay of about 600 ns, which is mainly caused by the circuit.

The calculated capacitance of the QWP device is 81 pF, and from this, a theoretical bandwidth of several hundred MHz can be estimated. However, the measured value is



Fig. 2. Photograph of the displayed THz light beam spot at the focus point of the second OAP.

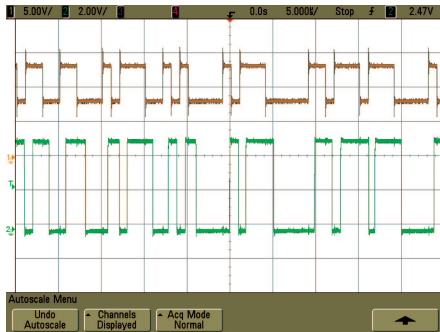

Fig. 3. Time traces of a 1.0-Mbps pseudorandom signal transmitted over the link.

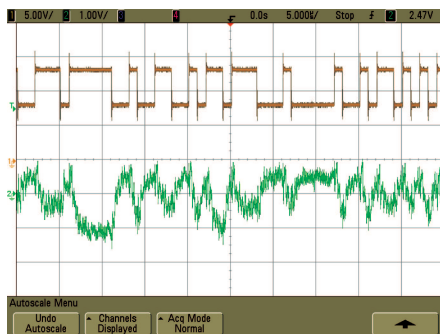

Fig. 4. Original waveform of a 1.0-Mbps pseudorandom signal generated by the THz QWP.

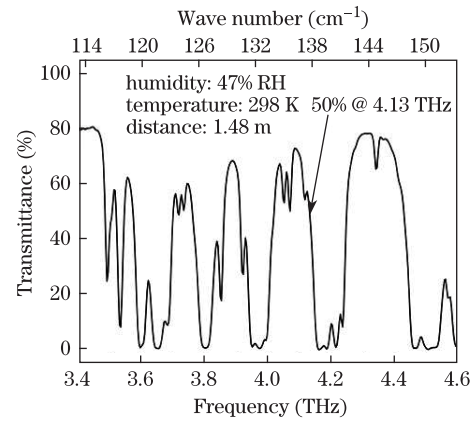

Fig. 5. Transmittance of the room-temperature atmosphere with a distance of 1.48 m at a relative humidity of 47%.

380 pF when the wires are connected to the electrodes of the QWP, and when the bottom contact of the detector is connected to the ground, because the sample holder of the cryostat is grounding. The capacitance was measured by a precision inductor capacitor resistor (LCR) meter (Agilent, 4285A), with measuring conditions of a 30-mV bias voltage and a 1.0-MHz frequency. In this case, the calculated 3-dB bandwidth was about 8 MHz by using an equivalent resistance-capacitance model. However, in our experimental case, the background current of the device is about 600 nA with a bias of -30 mV, whereas the photocurrent is about 150 nA as a result of the weak radiation reaching the detector. These are the main factors that lead to a low SNR of the transmission system and a limited bandwidth. Therefore, the connection between the device and the signal processor circuit should be optimized. Furthermore, the QCL device with higher output power should be employed in the future work.

The water-vapor absorption in the room-temperature atmosphere and the collection efficiency of the optical setup are the main factors that help reduce THz light power received by the detector when the transmission distance becomes longer, thereby limiting the transmission distance and the rate. The transmittance measured by a Fourier-transform spectrometer (Bruker, IFS 66v/S) at a relative humidity of 47% is shown in Fig. 5. The transmittance is 50% at 4.13 THz with an atmosphere distance of 1.48 m. A transmittance of 36% is deduced using the exponential attenuation equation in the uniform medium with a distance of 2.2 m. In our experiment, the light power received by the detector is only about 3.6% of the laser emission power, while considering collection efficiency or about 10% of the whole optical setup. This condition becomes worse when the distance is longer. Therefore, high collection efficiency reflectors and methods, along with a dry environment, should be employed to increase the transmission distance and rate in future works.

In conclusion, we demonstrate a 1.0-Mbps transmission link by employing a digitally-modulated THz QCL and a spectrally-matched QWP. The distance of the transmission link is 2.2 m, which is limited by the emission power of the laser. Both the THz QCL and QWP have high theoretical modulation bandwidths in the GHz region. However, in our experimental condition, the modulation speed is limited by the digital circuit and the power of

the emitter. Nonetheless, a common video would be transmitted easily by this link. We believe that the modulation speed can be significantly improved by increasing the power reaching to the receiver. In turn, such an increase reduces the size of the THz QWP and optimizes the circuits used in the emitter and the receiver.

This work was supported by the National “973” Program of China (No. 2011CB925603), the National “863” Program of China (No. 2011AA010205), the National Natural Science Foundation of China (No. 61131006), the Major National Development Project of Scientific Instrument and Equipment (No. 2011YQ150021), and the Shanghai Municipal Commission of Science and Technology (Nos. 09DJ1400102, 10JC1417000, and 11ZR1444200).

References

1. M. Tonouchi, *Nat. Photon.* **1**, 97 (2007).
2. R. Köhler, A. Tredicucci, F. Beltram, H. E. Beere, E. H. Linfield, A. G. Davies, D. A. Ritchie, R. C. Iotti, and F. Rossi, *Nature* **417**, 156 (2002).
3. S. Kumar, *IEEE J. Sel. Top. Quantum Electron.* **17**, 38 (2011).
4. J. C. Cao, H. Li, Y. J. Han, Z. Y. Tan, J. T. Lü, H. Luo, S. Laframboise, and H. C. Liu, *Chin. Phys. Lett.* **25**, 953 (2008).
5. S. Barbieri, W. Mauneult, S. S. Dhillon, C. Sirtori, J. Alton, N. Breuil, H. E. Beere, and D. A. Ritchie, *Appl. Phys. Lett.* **91**, 143510 (2007).
6. P. Gellie, S. Barbieri, J. F. Lampin, P. Filloux, C. Manquest, C. Sirtori, I. Sagnes, S. P. Khanna, E. H. Linfield, A. G. Davies, H. Beere, and D. Ritchie, *Opt. Express* **18**, 20799 (2010).
7. R. Martini and E. A. Whittaker, *J. Opt. Fiber Commun. Rep.* **2**, 279 (2005).
8. H. C. Liu, G. E. Jenkins, E. R. Brown, K. A. McIntosh, K. B. Nichols and M. J. Manfra, *IEEE Electron. Dev. Lett.* **16**, 253 (1995).
9. P. D. Grant, S. R. Laframboise, R. Dudek, M. Graf, A. Bezinger, and H. C. Liu, *Electron. Lett.* **45**, 952 (2009).
10. Z. Chen, Z. Y. Tan, Y. J. Han, R. Zhang, X. G. Guo, H. Li, J. C. Cao, and H. C. Liu, *Electron. Lett.* **47**, 1002 (2011).
11. H. Luo, H. C. Liu, C. Y. Song, and Z. R. Wasilewski, *Appl. Phys. Lett.* **86**, 231103 (2005).
12. H. Li, J. C. Cao, Z. Y. Tan, Y. J. Han, X. G. Guo, S. L. Feng, H. Luo, S. R. Laframboise, and H. C. Liu, *J. Phys. D: Appl. Phys.* **42**, 025101 (2009).